



Interlock® Tile Specification Manual

Interlock® Tile

Interlock Tile is an aluminum tile hidden fastener roofing system. It is specially designed to match the appearance of conventional tile roofing. The tile panels are coated with Alunar® for ultimate durability and protection. All trims are color matched to the specific Interlock color.

Interlock Tile provides outstanding advantages when compared to other roofing materials.

Durability

Unique design provides incredible strength and protects against severe weather.

Lightweight

Interlock Tile is very lightweight, having a dry or wet weight of 70 lbs. per 100 sq. ft. This is about 96% lighter than concrete or clay tile. Huge savings are realized in structural costs for new homes and developments, as truss systems can be designed for less stress and weight loads.

Low Maintenance

Design Flexibility

The look of tile is provided without the heavy cost of structural modifications. Interlock Tile can be adapted to almost any roof line and over most existing roofs.

Environmentally Friendly

Sustainable, recyclable and helps stop roofing material going to the landfill.

Lifetime Limited Warranty

Non-prorated, and one-time transferable.

Panel Fasteners are concealed to preserve authentic tile appearance & provides for panel expansion & contraction

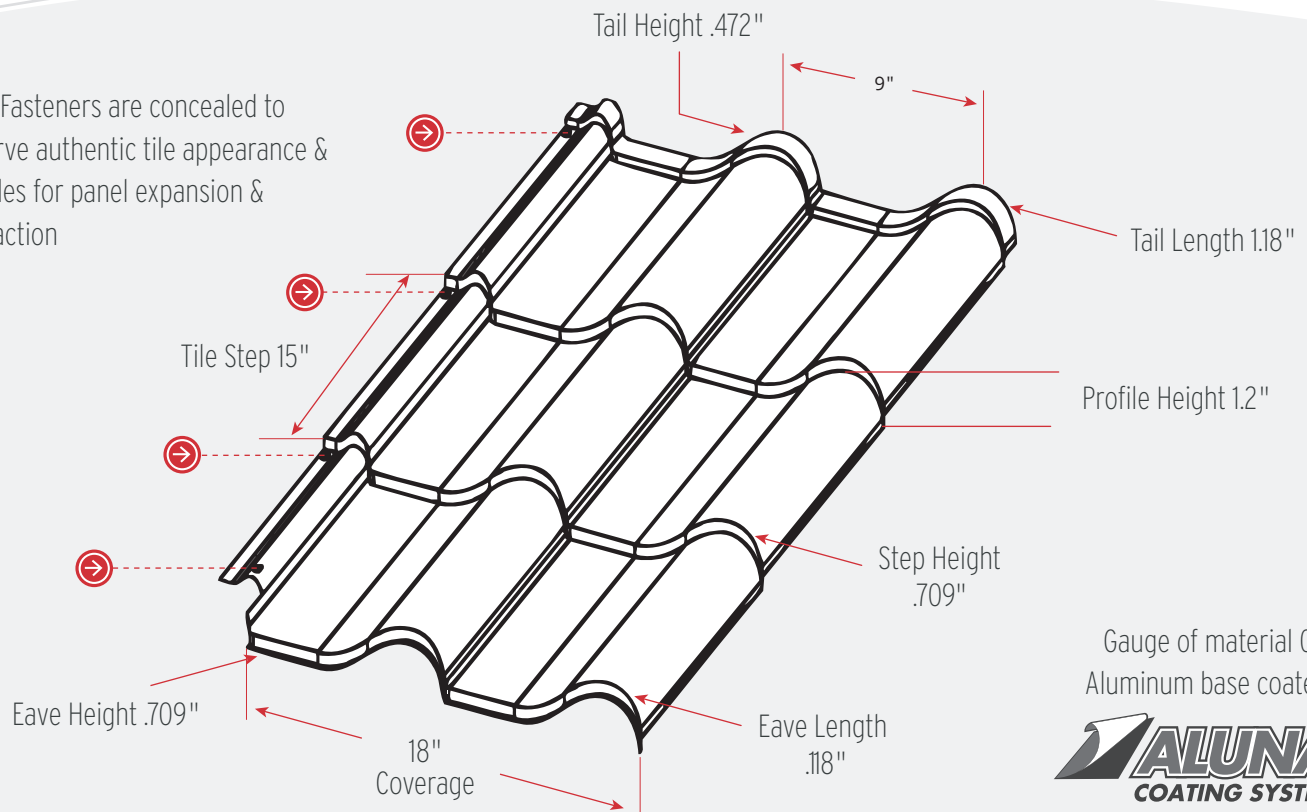

Roof Slope

Minimum 3:12 when installed with an ice & water underlayment or 4:12 minimum with synthetic underlayment.

Underlayment

The entire roof area is to be covered (prior to Tile application) with synthetic roofing underlayment.

Sheathing

Sheathing for the roof should not be less than 1/2". Optional - spaced over existing roof with strapping min. 1" x 4" spaced 15" on center.

Trusses

For new developments, enormous cost savings can be realized as Interlock® Tile weighs less than 4% the weight of concrete clay and tile, and much less than other roofing systems.

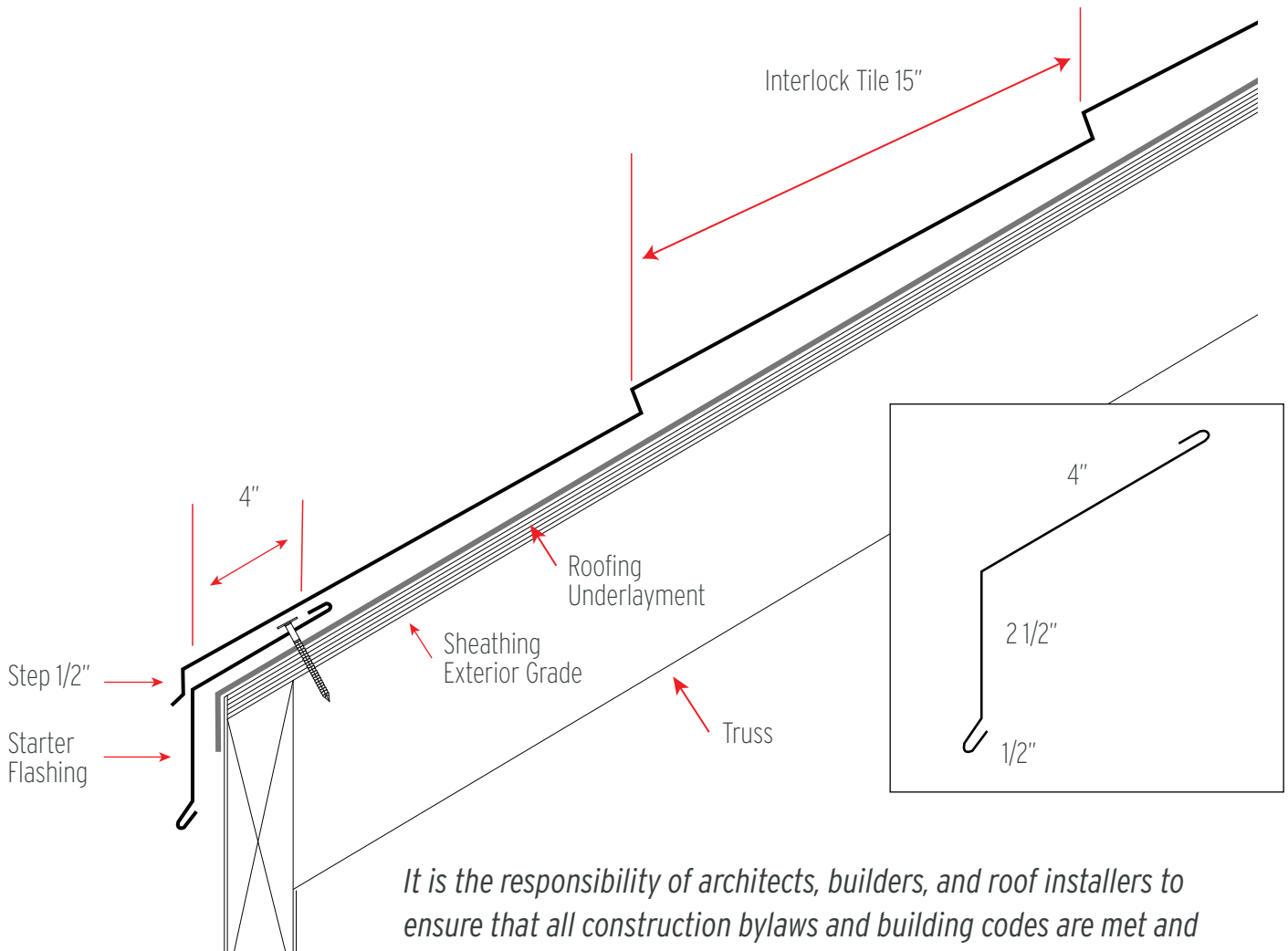

It is the responsibility of architects, builders, and roof installers to ensure that all construction bylaws and building codes are met and adhered to.

All Tile components are secured with non-corrosive stainless steel or aluminum fasteners.

All component trims are coated with the Alunar® Coating System and are based on standard 10 foot lengths except ridge, hip, and gable capping.

Screw fasteners are color matched to roof trims and components.

Tile Ridge Cap

Designed to complement any installation requirement, fitting any ridge or hip roof angle.

Manufactured in standard 48" lengths secured to C-Channel.

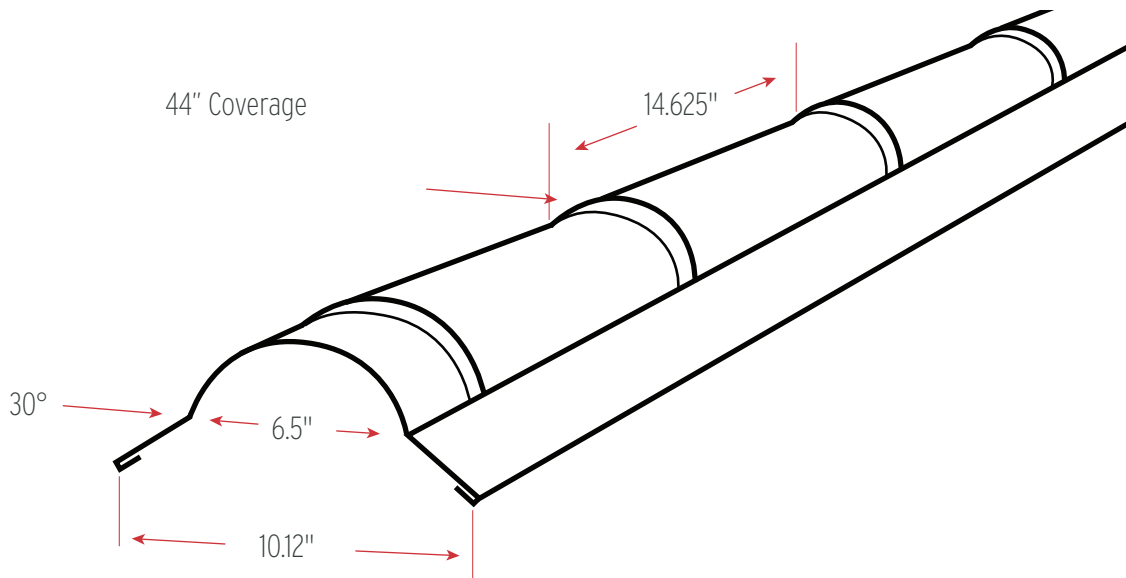

Tile Gable Cap

A specially designed component that lends beauty and structural superiority to the roofing system, while providing outstanding protection for gable ends.

Manufactured in standard 49" lengths secured to C-Channel.

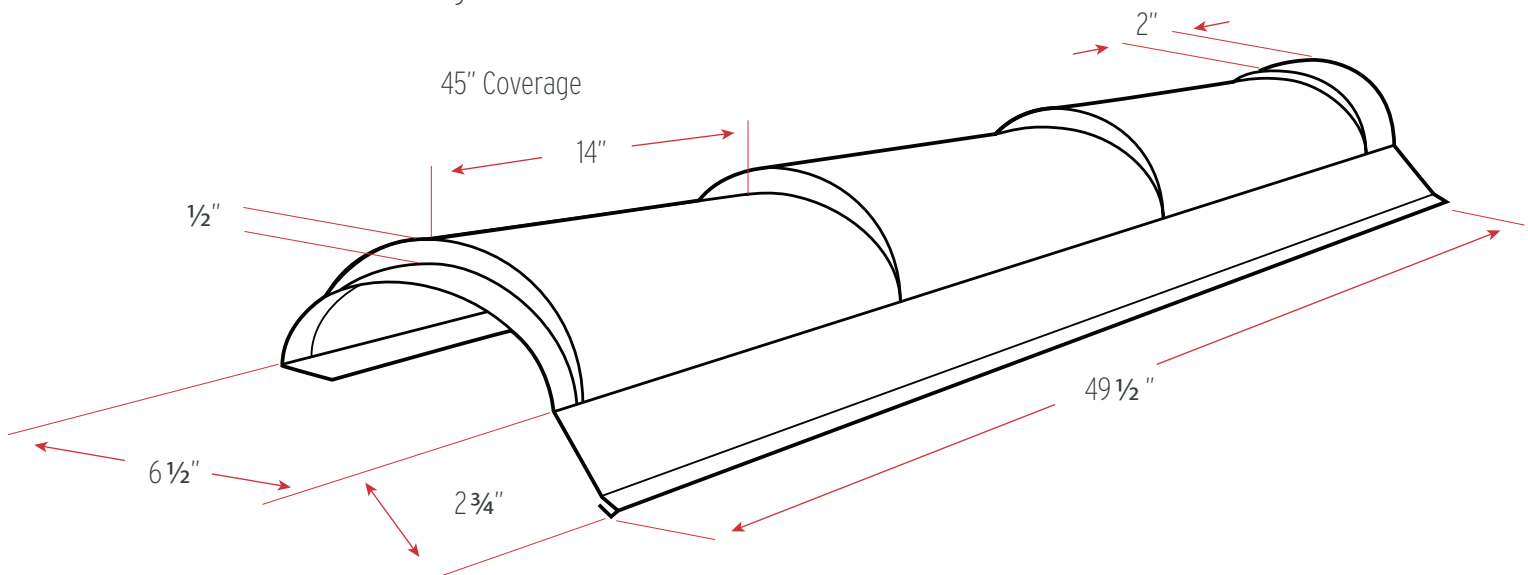

Starter Flashing

Carefully manufactured to give a greater degree of strength to the starter strip. The protruding edge is an effective drip cap which further reduces the possibility of capillary seepage.

Manufactured in 10' lengths.

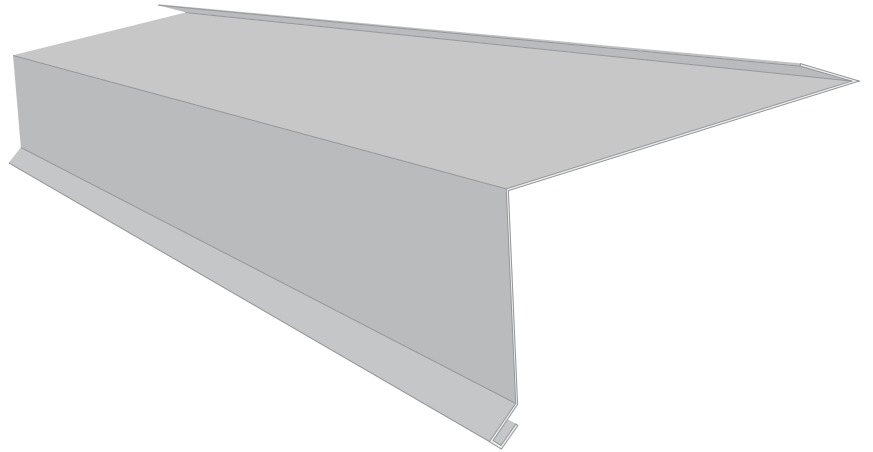
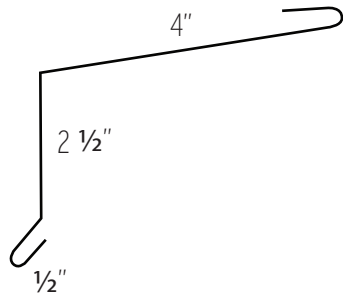

End Wall Trim

Provides a weathertight seal around chimneys, end walls, skylights, etc.

Manufactured in 10' lengths.

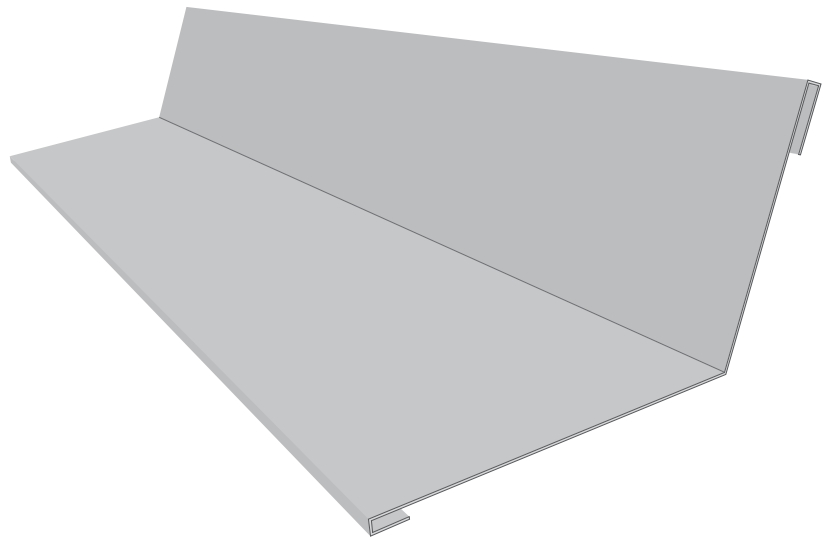
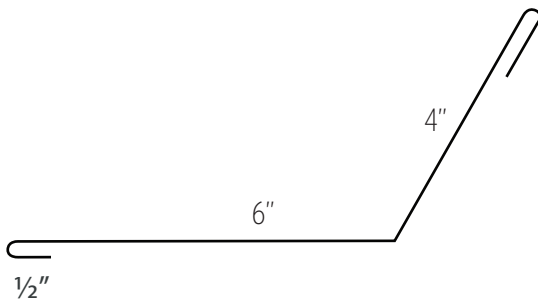

Side Wall Trim

Provides a weather-tight seal around chimneys, end walls, skylights, etc.

Manufactured in 10' lengths.

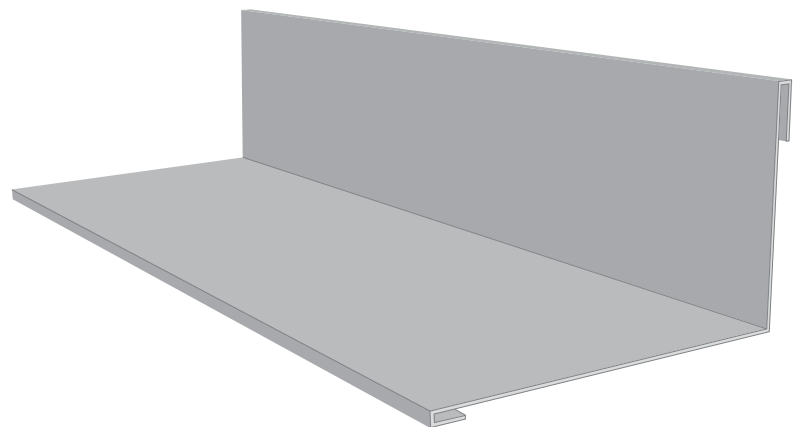
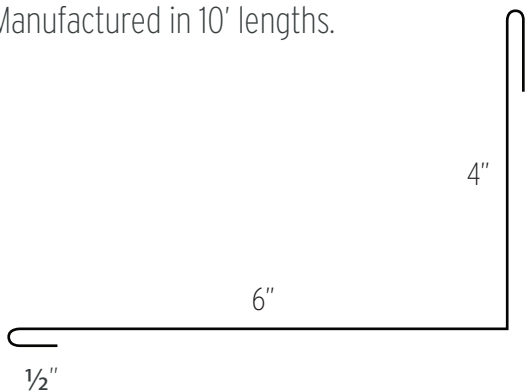

Valley Trim

Provides a smooth, obstruction-free path for precipitation - no projections to catch debris or snow. Panels are installed to form a solid weather-proof unit. This specially designed trim is manufactured in 10' lengths.

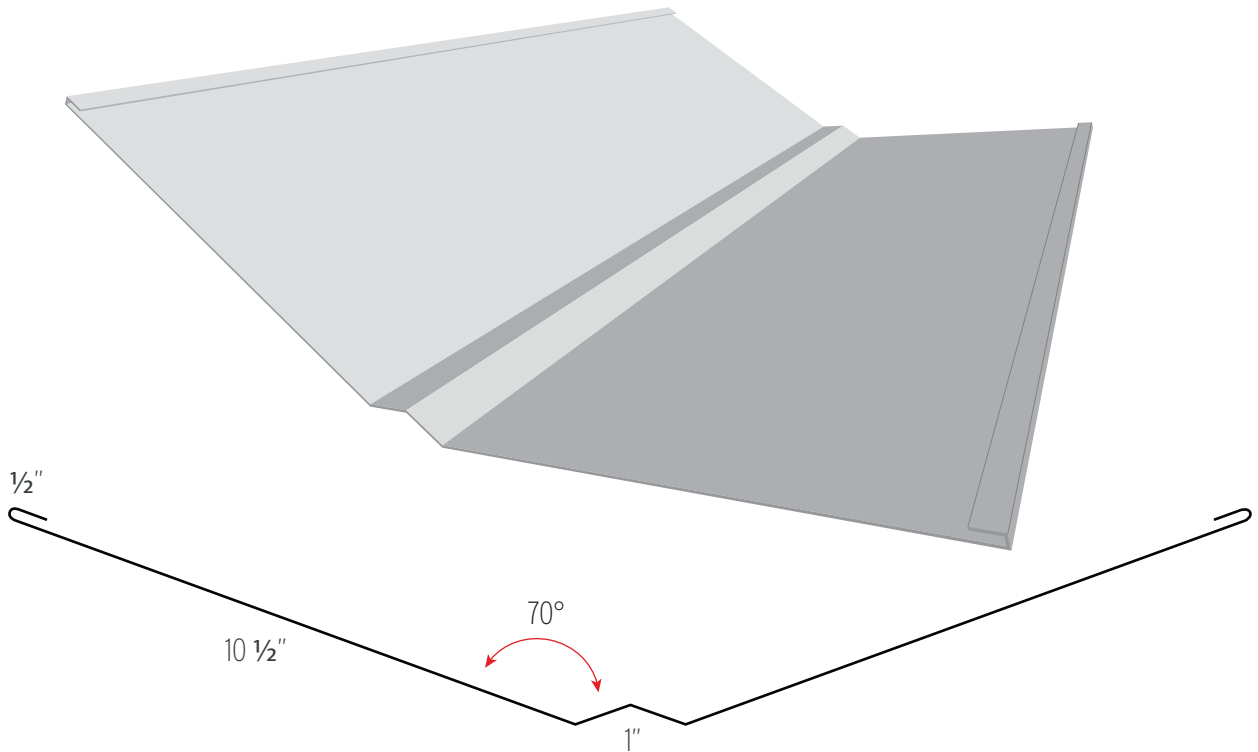

C-Channel

Technically designed to provide a secure base for Tile Ridge Caps and Gable Caps.

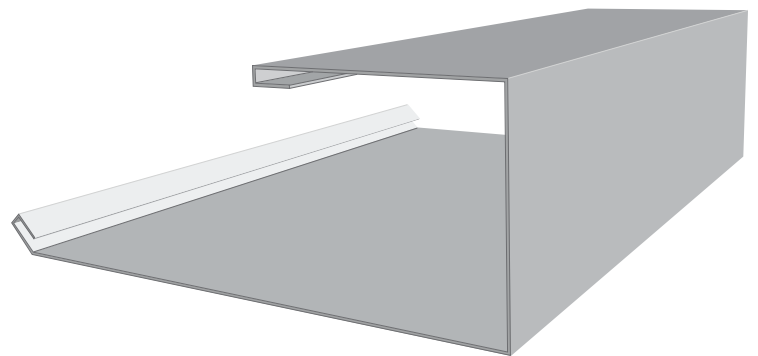
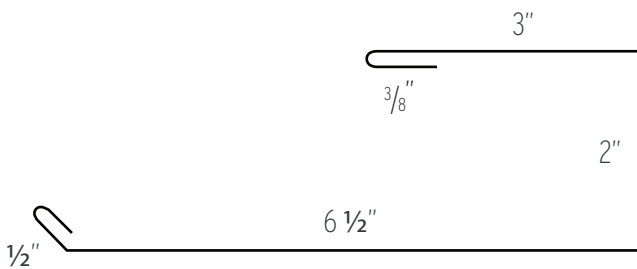

Plumbing Vent

A special flashing for plumbing stack pipes.

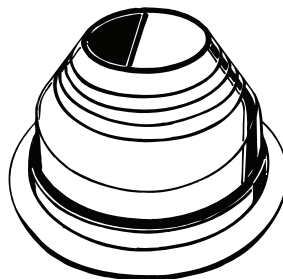

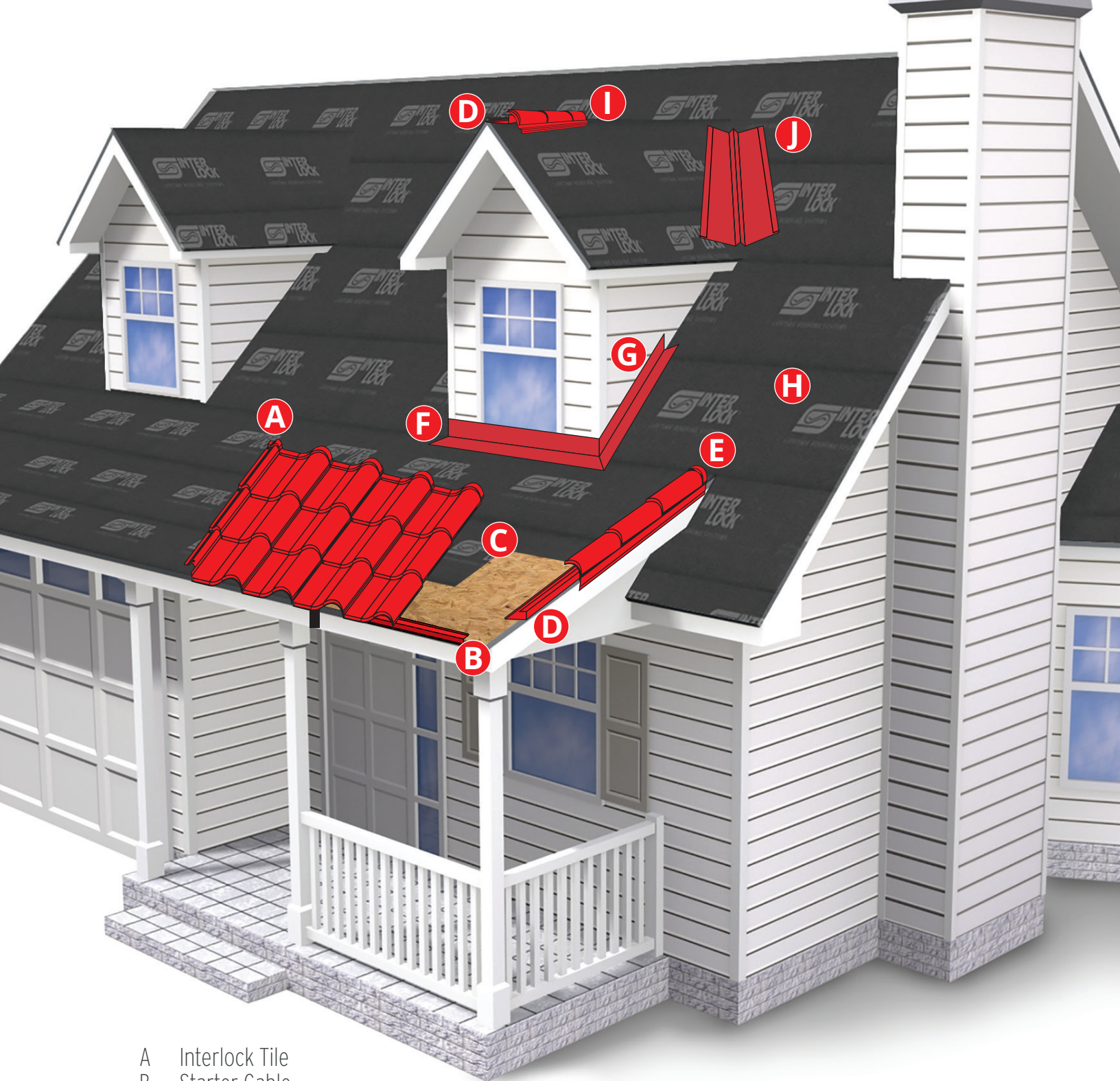

- A Interlock Tile
- B Starter Gable
- C 1/2" (min) Sheathing
- D C-Channel
- E Tile Gable Cap
- F Endwall Trim
- G Side Wall Flashing
- H Underlayment
- I Tile Ridge Cap
- J Valley Trim

Testing Reports

ICC Evaluation Report 1790
 Florida Report FL 7263
 Texas Department of Insurance
 - Hail Impact UL2218 Class IV

Color Guide

Interlock Roofing Ltd. offers a highly durable aluminum roofing product available in a range of different colors, opening up an extensive palette for homeowners and designers. Interlock® roofs are exclusively protected for a lifetime by the Alunar® Coating System.



Solid Copper



Copper Penny

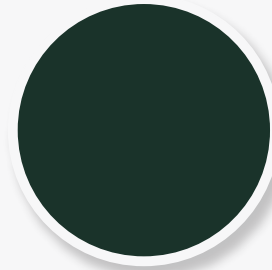

Hunter Green

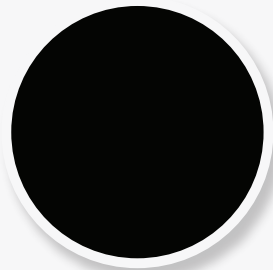

Black

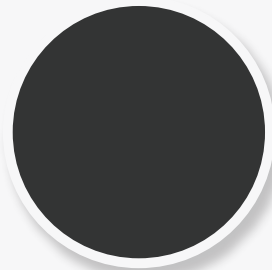

Deep Charcoal

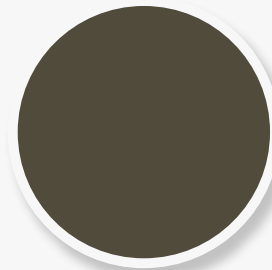

Musket Grey

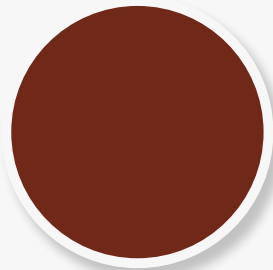

Tile Red

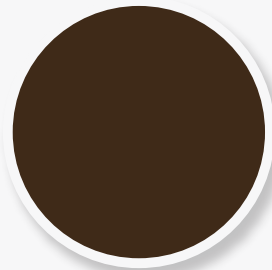

Colonial Brown

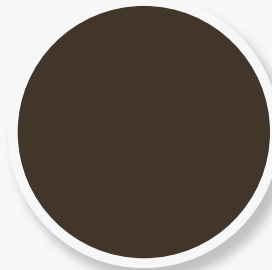

Tudor Brown



Color and availability may change without notice. Product design and installation technique may vary from represented shown on manual. Installation methods may vary by structure, region, climate, and local building codes. Certain variables and factors specific to your home may inhibit the product's ability to shed snow. Roofing products and components may change without notice. Please see our website for more information.